

PRECISMECA - MONTAN

Tragrollenträger

und Zubehör

Roller supports

and accessories

Erzeugnisbeschreibung /		Description of products
Bezeichnung / Typ Description / type		Blatt Nr. Sheet no.
Stehbock Supporting trestle	Typ SB Type SB	501
Haltewinkel Supporting bracket	Typ HW Type HW	502
Rollenträger Roller support	Typ E Type E	511
Rollenträger Roller support	Typ AL Type AL	521
Rollenträger Roller support	Typ PS Type PS	522
Rollenträger Roller support	Typ U Type U	523
Rollenträger Roller support	Typ U Type U	524
Lenkrollenträger Training support	Typ OLU Type OLU	532
Klemmbefestigung Clamping device	Typ OF Type OF	551
Schraubbefestigung Fixing device	Typ SF Type SF	552
9/03		Blatt Sheet 500

PRECISMECA - MONTAN

STEHBOCK SUPPORTING TRESTLE TYP SB	FÜR EINTEILIGE STATIONEN FOR ONE PARTED STATIONS	OBERBAND CARRYING BELT
---	---	-----------------------------------

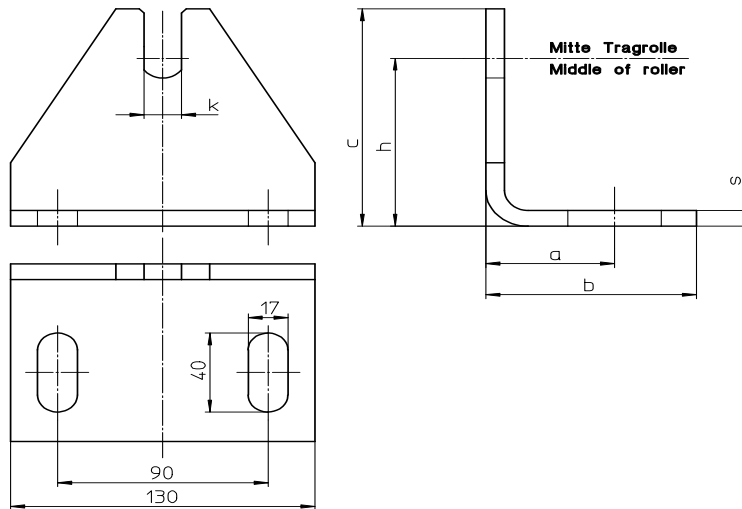

Tragrolle Idler		Stehbock Supporting trestle						Masse [kg] Weight [kg]	Bestell-Nr Order-no.
D [mm]	SW [mm]	a [mm]	b [mm]	c [mm]	h [mm]	k [mm]	s [mm]		
63 89 108 133	14/15	55	90	110	85	16	8	1,4	501/ 1
89 108 133 159	18	80	115	110	85	19	8	2,0	501/ 2
108 133 159 194	22	80	115	120	75	23	10	2,0	501/ 3

Konservierung: verzinkt, andere Ausführungen auf Anfrage Lieferung: Tragrollen und Befestigungsmittel sind gesondert zu bestellen
 Painting: zinc plated, other performance on request Delivery: Rollers and fasteners please ordered separately

9/02	Bestellangaben: Stehbock SB 22 (Nr. 501/3) Order details: Supporting trestle SB 22 (no. 501/3)	Blatt Sheet 501
------	---	------------------------------

PRECISMECA - MONTAN

HALTEWINKEL SUPPORTING BRACKET TYP HW	FÜR EINTEILIGE UNTERBANDSTATIONEN FOR ONE PARTED RETURN-STATIONS	UNTERBAND RETURN BELT
--	---	----------------------------------

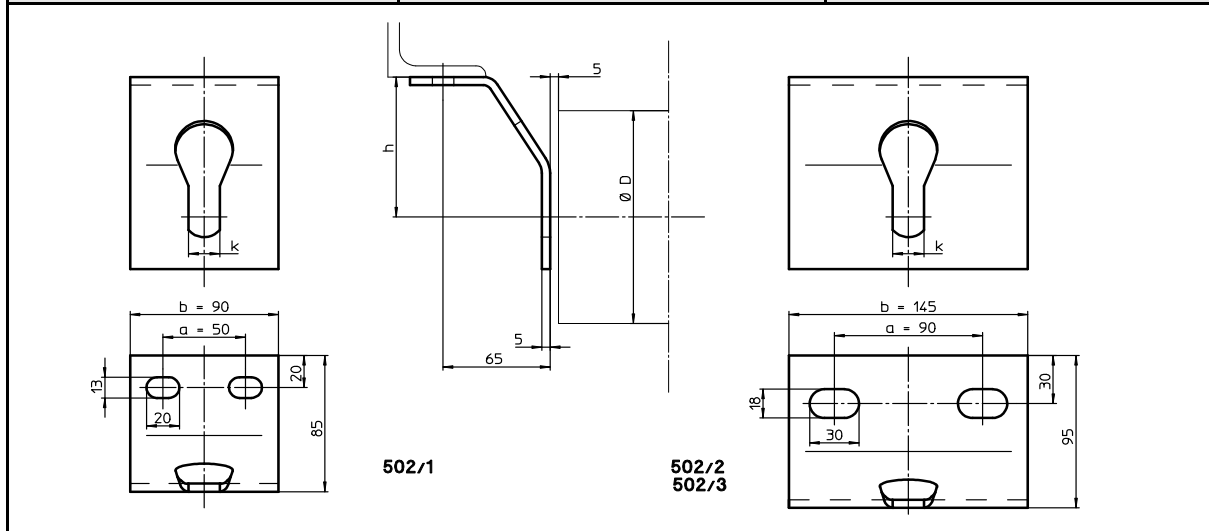

Tragrolle Idler		Haltewinkel Supporting bracket				Masse [kg] Weight [kg]	Bestell-Nr Order-no.
D [mm]	SW [mm]	a [mm]	b [mm]	h [mm]	k [mm]		
63 89 108	14/15	50	90	70	16	0,5	502/ 1
89 108 133 159	18	90	145	100	19	1,0	502/ 2
108 133 159	22	90	145	100	23	1,0	502/ 3

Konservierung: verzinkt, andere Ausführungen auf Anfrage Lieferung: Tragrollen und Befestigungsmittel sind gesondert zu bestellen
 Painting: zinc plated, other performance on request Delivery: Rollers and fasteners please ordered separately

9/02	Bestellangaben: Haltewinkel HW 22 (Nr. 502/3) Order details: Supporting bracket HW 22 (no. 502/3)	Blatt Sheet 502
------	--	------------------------------

PRECISMECA - MONTAN

ROLLENTRÄGER ROLLER SUPPORT TYP E	FÜR ZWEITEILIGE STATIONEN FOR TWO PARTED STATIONS	OBERBAND CARRYING BELT
--	--	-----------------------------------

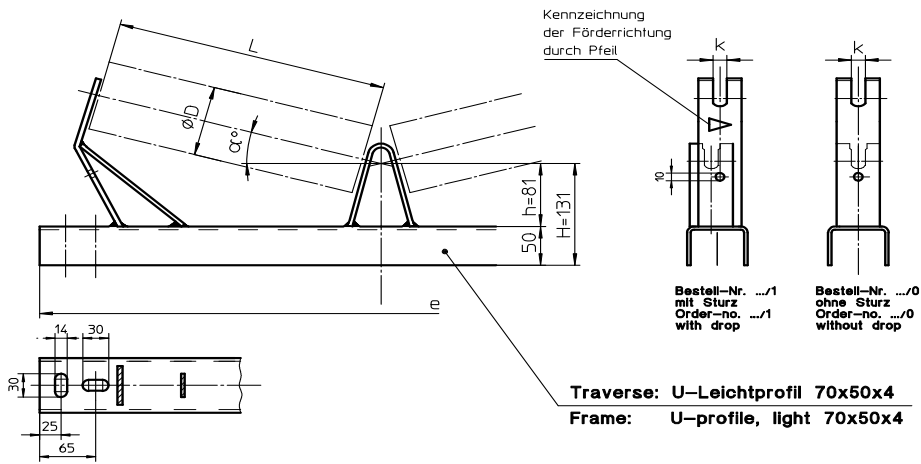

Gurtbreite Belt width b [mm]	Tragrolle Roller			Träger Support				Masse Weight [kg]	Bestell-Nr Order-no.	
	D [mm]	L [mm]	SW [mm]	e [mm]	h [mm]	k [mm]	α [°]		mit with Sturz drop	ohne without
300	63	200	14/15	590	81	16	15	3,5	511/1/1	511/1/0
400		250		690					511/2/1	511/2/0
500	315	790		511/3/1				511/3/0		
650	89	380		940				511/4/1	511/4/0	
800		465		1140				511/5/1	511/5/0	

Konservierung: verzinkt, andere Ausführungen auf Anfrage

Painting: zinc plated, other performance on request

Lieferung: Tragrollen und Befestigungsmittel für die Befestigungsarten geschraubt und geklemmt sind gesondert zu bestellen.

Delivery: Rollers and fasteners for screwed and clamped fixing please ordered separately.

(siehe Blatt 551/552)

(look sheet 551/552)

9/02

Bestellangaben: Träger E- 500- SW 14/15 (Nr. 511/3/1)
Order details: Support E- 500- SW14/15 (no. 511/3/1)

Blatt
Sheet
511

PRECISMECA - MONTAN

ROLLENTRÄGER ROLLER SUPPORT TYP AL	FÜR DREITEILIGE STATIONEN FOR THREE PARTED STATIONS	OBERBAND CARRYING BELT
---	--	-----------------------------------

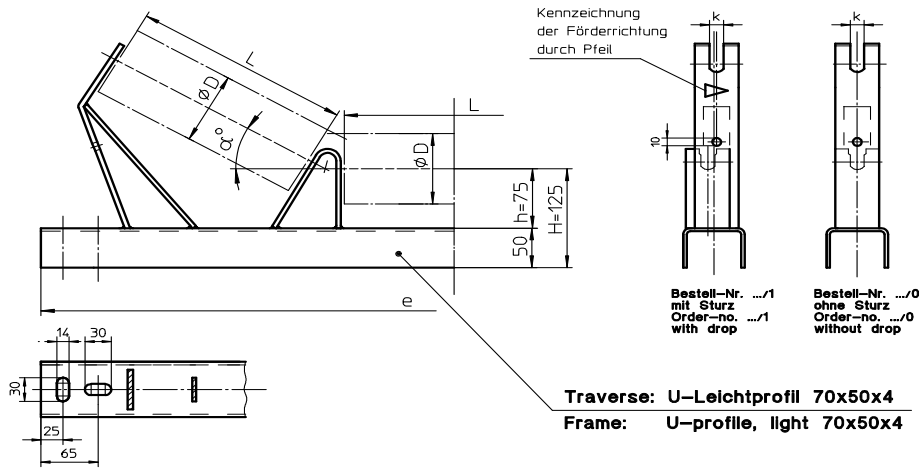

Gurtbreite Belt width b [mm]	Tragrolle Idler			Träger Support				Masse Weight [kg]	Bestell-Nr Order-no.	
	D [mm]	L [mm]	SW [mm]	e [mm]	h [mm]	k [mm]	α [°]		mit with	ohne without
500	63	200	14/15	790	75	16	15	5,9	521/ 1/1	521/ 1/0
							20	6,0	521/ 2/1	521/ 2/0
							25	6,1	521/ 3/1	521/ 3/0
							30	6,3	521/ 4/1	521/ 4/0
							35	6,5	521/ 5/1	521/ 5/0
650	63	250	14/15	940	75	16	15	6,7	521/ 6/1	521/ 6/0
							20	6,9	521/ 7/1	521/ 7/0
							25	7,0	521/ 8/1	521/ 8/0
							30	7,2	521/ 9/1	521/ 9/0
							35	7,4	521/10/1	521/10/0
800	89	315	14/15	1140	75	16	15	7,8	521/11/1	521/11/0
							20	8,0	521/12/1	521/12/0
							25	8,2	521/13/1	521/13/0
							30	8,4	521/14/1	521/14/0
							35	8,6	521/15/1	521/15/0
1000	108	380	14/15	1340	75	16	15	8,9	521/16/1	521/16/0
							20	9,1	521/17/1	521/17/0
							25	9,3	521/18/1	521/18/0
							30	9,5	521/19/1	521/19/0
							35	9,8	521/20/1	521/20/0
1200	108	465	14/15	1590	75	16	15	10,3	521/21/1	521/21/0
							20	10,6	521/22/1	521/22/0
							25	10,8	521/23/1	521/23/0
							30	11,2	521/24/1	521/24/0
							35	11,6	521/25/1	521/25/0

Konservierung: verzinkt, andere Ausführungen auf Anfrage
 Painting: zinc plated, other performance on request
 Lieferung: Tragrollen und Befestigungsmittel für die Befestigungsarten geschraubt und geklemmt sind gesondert zu bestellen.
 Delivery: Rollers and fasteners for screwed and clamped fixing please ordered separately. (siehe Blatt 551/552)
 (look sheet 551/552)

9/02	Bestellangaben:	Träger AL- 650- 30° SW 14/15 (Nr.521/9/1)	
	Order details:	Support AL- 650- 30° SW14/15 (no. 521/9/1)	
		Blatt Sheet 521	

PRECISMECA - MONTAN

ROLLENTRÄGER ROLLER SUPPORT TYP PS	FÜR DREITEILIGE STATIONEN FOR THREE PARTED STATIONS	OBERBAND CARRYING BELT
---	--	-----------------------------------

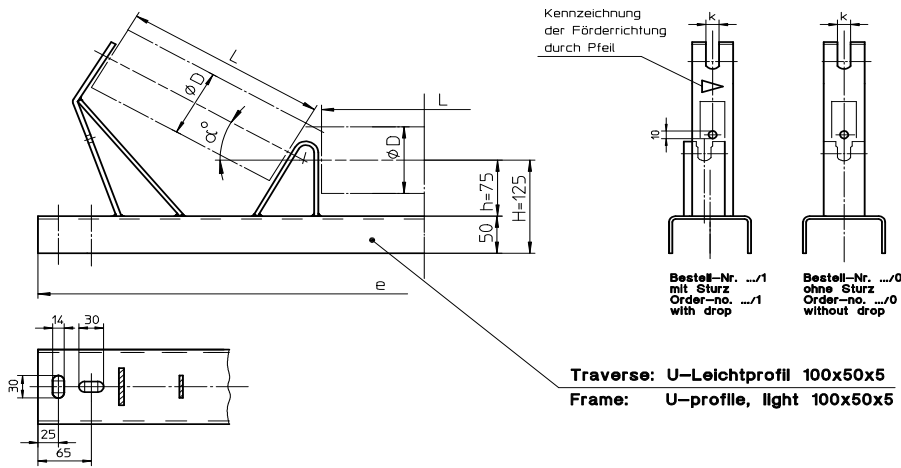

Gurtbreite Belt width b [mm]	Tragrolle Idler			Träger Support				Masse Weight [kg]	Bestell-Nr Order-no.	
	D [mm]	L [mm]	SW [mm]	e [mm]	h [mm]	k [mm]	α [°]		mit with Sturz drop	ohne without
500	89	200	14/15	790	75	16	20	7,6	522/ 1/1	522/ 1/0
							30	8,0	522/ 2/1	522/ 2/0
							35	8,2	522/ 3/1	522/ 3/0
							40	8,6	522/ 4/1	522/ 4/0
650	108	250	14/15	940	75	16	20	8,7	522/ 5/1	522/ 5/0
							30	9,3	522/ 6/1	522/ 6/0
							35	9,6	522/ 7/1	522/ 7/0
							40	10,0	522/ 8/1	522/ 8/0
800	133	315	14/15	1140	75	16	20	10,4	522/ 9/1	522/ 9/0
							30	11,0	522/10/1	522/10/0
							35	11,3	522/11/1	522/11/0
							40	11,8	522/12/1	522/12/0
1000	133	380	14/15	1340	75	16	20	11,9	522/13/1	522/13/0
							30	12,6	522/14/1	522/14/0
							35	12,9	522/15/1	522/15/0
							40	13,3	522/16/1	522/16/0
1200	133	465	14/15	1590	75	16	20	14,3	522/17/1	522/17/0
							30	15,0	522/18/1	522/18/0
							35	15,3	522/19/1	522/19/0
							40	16,1	522/20/1	522/20/0

Konservierung: verzinkt, andere Ausführungen auf Anfrage
 Painting: zinc plated, other performance on request
 Lieferung: Tragrollen und Befestigungsmittel für die Befestigungsarten geschraubt und geklemmt sind gesondert zu bestellen.
 Delivery: Rollers and fasteners for screwed and clamped fixing please ordered seperately. (siehe Blatt 551/552)
 (look sheet 551/552)

9/02	Bestellangaben: Order details:	Träger PS- 650- 30° SW 14/15 (Nr.522/6/1) Support PS- 650- 30° SW14/15 (no. 522/6/1)	Blatt Sheet 522
------	---	---	------------------------------

PRECISMECA - MONTAN

ROLLENTRÄGER ROLLER SUPPORT TYP U	FÜR DREITEILIGE STATIONEN FOR THREE PARTED STATIONS	OBERBAND CARRYING BELT
--	--	-----------------------------------

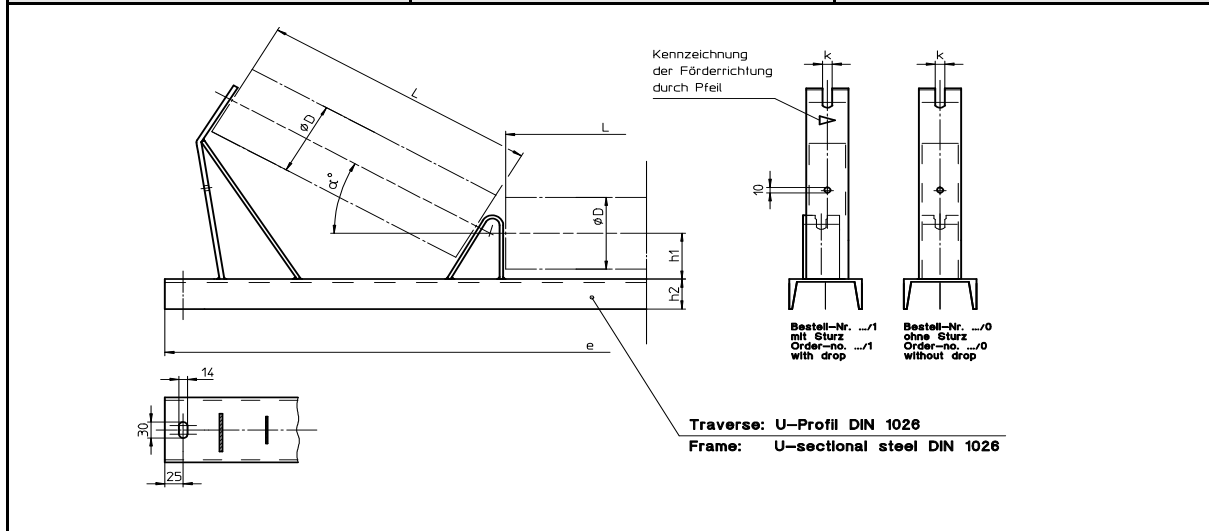

Gurtbreite Belt width b [mm]	Tragrolle Idler			Träger Support						Masse Weight [kg]	Bestell-Nr Order-no.	
	D [mm]	L [mm]	SW [mm]	e [mm]	h1 [mm]	h2 [mm]	k [mm]	Traverse Frame	α [°]		mit with Sturz drop	ohne without
1000	89	380	14/15	1340	75	50	16	U 100	10	16,8	523/ 1/1	523/ 1/0
									20	17,6	523/ 2/1	523/ 2/0
									30	19,2	523/ 3/1	523/ 3/0
									35	19,8	523/ 4/1	523/ 4/0
									40	20,2	523/ 5/1	523/ 5/0
1200	133	465	14/15	1590	85	55	16	U 120	10	26,8	523/ 6/1	523/ 6/0
									20	28,2	523/ 7/1	523/ 7/0
									30	30,9	523/ 8/1	523/ 8/0
									35	31,4	523/ 9/1	523/ 9/0
									40	31,7	523/10/1	523/10/0

Konservierung: verzinkt, andere Ausführungen auf Anfrage

Painting: zinc plated, other performance on request

Lieferung: Tragrollen und Befestigungsmittel sind gesondert zu bestellen.

Delivery: Rollers and fasteners please ordered seperately.

(siehe Blatt 552)

(look sheet 552)

9/02	Bestellangaben:	Träger U-1000- 30° SW 14/15 (Nr.523/3/1)	
	Order details:	Support U-1000- 30° SW14/15 (no. 523/3/1)	
			Blatt Sheet 523

PRECISMECA - MONTAN

ROLLENTRÄGER ROLLER SUPPORT TYP U	FÜR DREITEILIGE STATIONEN FOR THREE PARTED STATIONS	OBERBAND CARRYING BELT
--	--	-----------------------------------

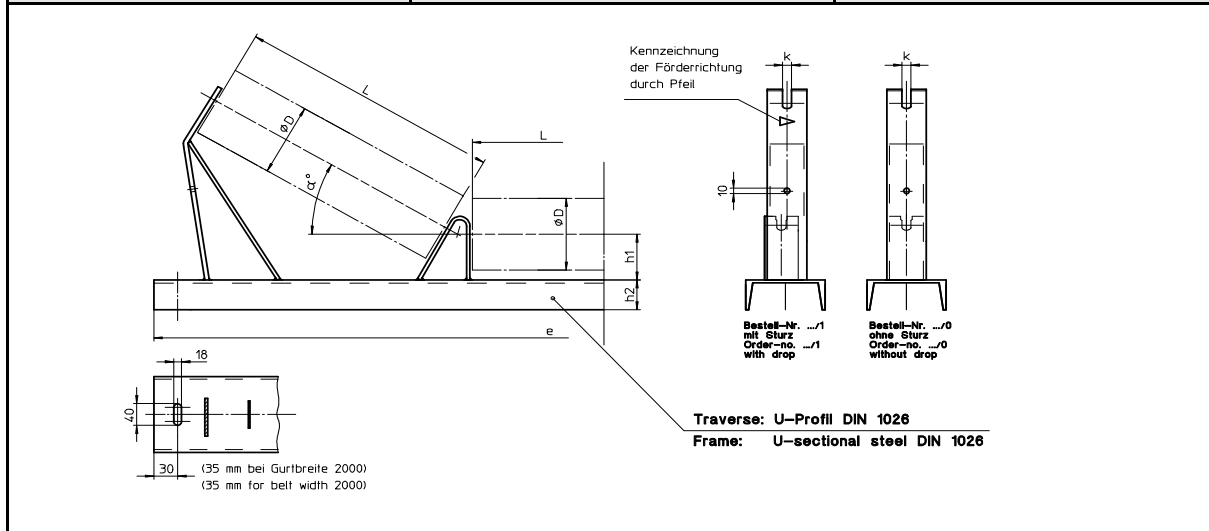

Gurtbreite Belt width b [mm]	Tragrolle Idler			Träger Support						Masse Weight [kg]	Bestell-Nr Order-no.		
	D [mm]	L [mm]	SW [mm]	e [mm]	h1 [mm]	h2 [mm]	k [mm]	Traverse Frame	α [°]		mit with Sturz drop	ohne without	
1400	108	530	22	1790	100	60	23	U 140		10	35,9	524/ 1/1	524/ 1/0
										20	37,4	524/ 2/1	524/ 2/0
										30	39,5	524/ 3/1	524/ 3/0
										35	40,7	524/ 4/1	524/ 4/0
										40	41,7	524/ 5/1	524/ 5/0
1600	159	600	32	2040	130	65	33	U 160		10	40,3	524/ 6/1	524/ 6/0
										20	42,0	524/ 7/1	524/ 7/0
										30	44,3	524/ 8/1	524/ 8/0
										35	45,6	524/ 9/1	524/ 9/0
										40	46,7	524/10/1	524/10/0
1800	133	670	32	2240	130	65	33	U 160		10	54,0	524/11/1	524/11/0
										20	56,6	524/12/1	524/12/0
										30	60,2	524/13/1	524/13/0
										35	61,2	524/14/1	524/14/0
										40	63,1	524/15/1	524/15/0
2000	194	750	32	2490	130	70	33	U 180		10	67,6	524/16/1	524/16/0
										20	71,2	524/17/1	524/17/0
										30	75,2	524/18/1	524/18/0
										35	77,0	524/19/1	524/19/0
										40	78,6	524/20/1	524/20/0

Konservierung: verzinkt, andere Ausführungen auf Anfrage

Painting: zinc plated, other performance on request

Lieferung: Tragrollen und Befestigungsmittel sind gesondert zu bestellen.

Delivery: Rollers and fasteners please ordered separately.

(siehe Blatt 552)

(look sheet 552)

9/02	Bestellangaben:	Träger U-1600- 30° SW 22	(Nr.524/8/1)		Blatt Sheet 524
	Order details:	Support U-1600- 30° SW 22	(no. 524/8/1)		

PRECISMECA - MONTAN

LENKROLLENTRÄGER TRAINING SUPPORT TYP OLU

UNTERBAND RETURN BELT

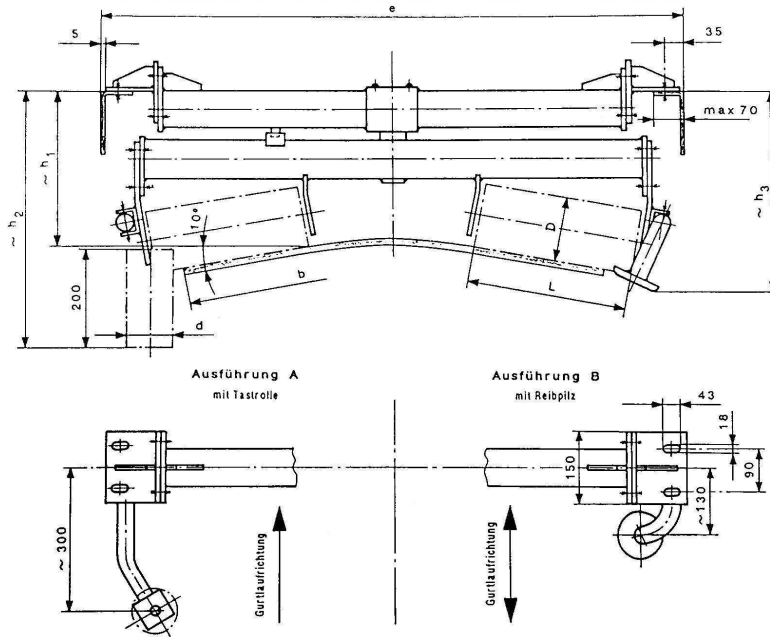

Gurtbreite Belt width b [mm]	Tragrolle Idler				Tastrolle Guide roller						Masse Weight ohne Rollen/ without roller [kg]	Bestell-Nr Order-no. 1)
	D [mm]	L [mm]	Lager Bearing	siehe Blatt find at sheet	D [mm]	siehe Blatt find at sheet	e [mm]	h1 [mm] *)	h2 [mm] *)	h3 [mm] *)		
650	108	250	6204	131	60	421/5/1	950	280	420	355	32,7	532/ 1/1
800		315					1150	330	470	420	34,6	532/ 2/1
1000		380					1350	330	470	430	36,7	532/ 3/1
1200		465					1600	330	470	445	39,1	532/ 4/1
650	133	250	6305	143	89	421/5/2	950	315	495	315	35,5	532/ 5/1
800		315					1150	315	495	315	37,2	532/ 6/1
1000		380					1350	315	495	315	39,5	532/ 7/1
1200		465					1600	315	495	315	42,3	532/ 8/1
1400		530	6306	145			1800	380	575	535	64,2	532/ 9/1
1600		600					2050	380	575	535	68,3	532/10/1

1) Lieferung in Ausführung B - mit Reibpilz - für Reversierbetrieb. *) ± 32 mm höhenverstellbar
 Delivery in design B - with friction tops - for conveyors with variable belt direction. *) ± 32 mm to move vertically
 Die Bestell-Nr. verändert sich dabei wie folgt : 532/ ... /2
 Please order with changed purchase no.: 532/ ... /2

Konservierung: Träger und Reibpilze mit Grundanstrich 60µm, andere Ausführungen auf Anfrage.

Painting: Support and friction tops with base painting 60 µm, other performance on request.

Lieferung: Träger mit Tastrollen bzw. Reibpilzen. Tragrollen sind gesondert zu bestellen !

Delivery: Support with guide roller respectively friction tops. Rollers and fasteners please order seperately.

9/02

Bestellangaben: Lenkrollenstation OLU-1200-10-108x465-6204-/(Nr. 532/4/1)
Order details: Training support OLU-1200-10-108x465-6204-A (no. 532/4/1)

Blatt
Sheet
532

PRECISMECA - MONTAN

KLEMMBEFESTIGUNG CLAMPING DEVICE TYP OF	FÜR TRAGROLLENTRÄGER FOR ROLLER SUPPORTS TYP E - TYP AL - TYP PS	OBERBAND CARRYING BELT
--	---	-----------------------------------

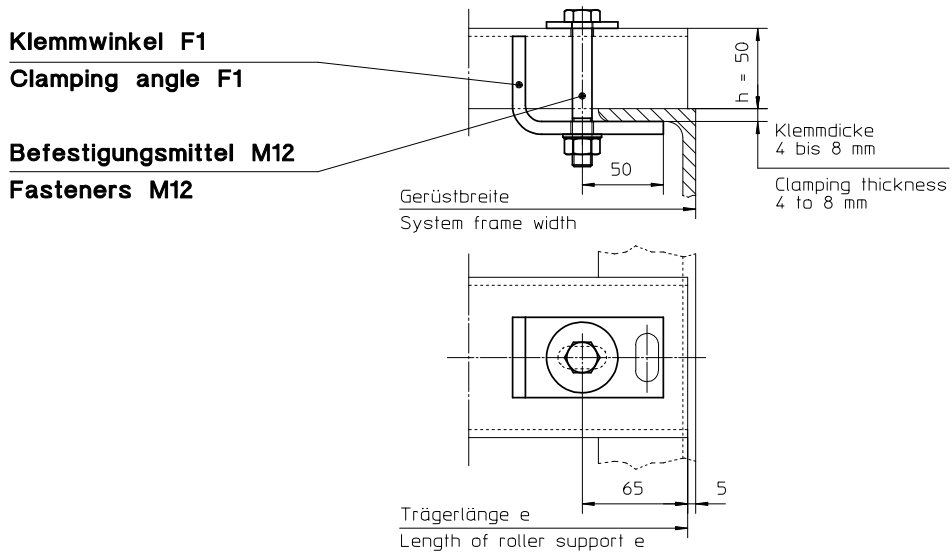

Rollenträger Roller support	Klemmbefestigung Clamping device			Masse [kg] Weight [kg]	Bestell-Nr Order-no.
	Klemmwinkel Clamping angle	Befestigungsmittel Fasteners	h [mm]		
Typ E					
Typ AL	F1	M12	50	0,6	551/ 1
Typ PS					

Konservierung: verzinkt, andere Ausführungen auf Anfrage

Painting: zinc plated, other performance on request

9/02	Bestellangaben: Klemmbefestigung OF1 (Nr.551/1) Order details: Clamping device OF1 (no. 551/1)	Blatt Sheet 551
------	---	------------------------------

PRECISMECA - MONTAN

SCHRAUBBEFESTIGUNG FIXING DEVICE TYP SF	FÜR TRAGROLLENTRÄGER FOR ROLLER SUPPORTS	OBERBAND CARRYING BELT
--	---	-----------------------------------

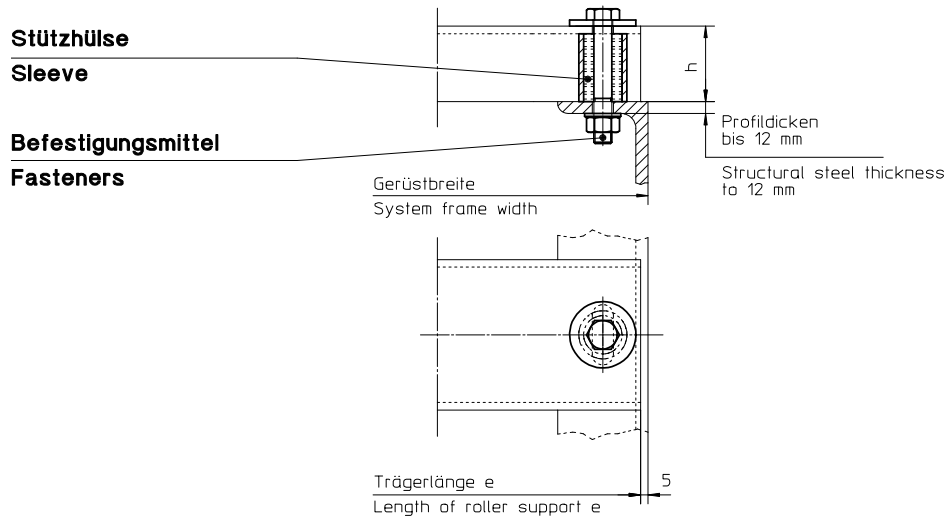

Rollenträger Roller support	Schraubbefestigung Fixing device			Masse [kg] Weight [kg]	Bestell-Nr Order-no.
	Stützhülse Sleeve	Befestigungsmittel Fasteners	h [mm]		
Typ E Typ AL	ohne / without	M12	50	0,15	552/1
Typ PS Typ U-1000	S2	M12	50	0,3	552/2
Typ U-1200	S3	M12	55	0,3	552/3
Typ U-1400 Typ U-1600	S4	M16	60	0,4	552/4
Typ U-1800	S5	M16	65	0,45	552/5
Typ U-2000	S6	M16	70	0,5	552/6

Konservierung: verzinkt, andere Ausführungen auf Anfrage

Painting: zinc plated, other performance on request

9/02	Bestellangaben: Schraubbefestigung SF2 (Nr.552/2) Order details: Fixing device SF2 (no. 552/2)	Blatt Sheet 552
------	---	------------------------------